

SeyWave® Wireless Access System

Model: SW-PCD

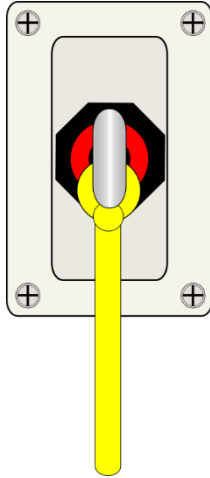

- Wireless Pull Cord operator
- Status LED for indication
- SeyWave® wireless technology for dependable communication
- Powered from standard AA batteries

Product Description

The SeyWave® Wireless Pull Cord operator was designed to allow users the flexibility and convenience of remote activation, without the expense of running conduit. Yellow pull cord makes activation easy and accessible.

Product Specifications

Operating Specifications				
	Min	Typ	Max	Unit
Operating Voltage ⁽¹⁾	2.4	3	5	VDC
Operating Current	3	5	1800	uA
Operating Frequency		2.4		GHz
Operating Range			150	ft(LOS)

Notes: (1) Alkaline or LiFeS₂ type AA batteries only

Environmental Specifications	
Operating Temperature	-25C to 60C (-13F to 140F)
UL Type / Ingress Protection	UL Type 1, 4, 4x & 6 / IP66/67

"This device complies with Part 15 of the FCC Rules. Operation is subject to the following two conditions: (1) This device may not cause harmful interference, and (2) this device must accept any interference received, including interference that may cause undesired operation."*

Product Dimensions

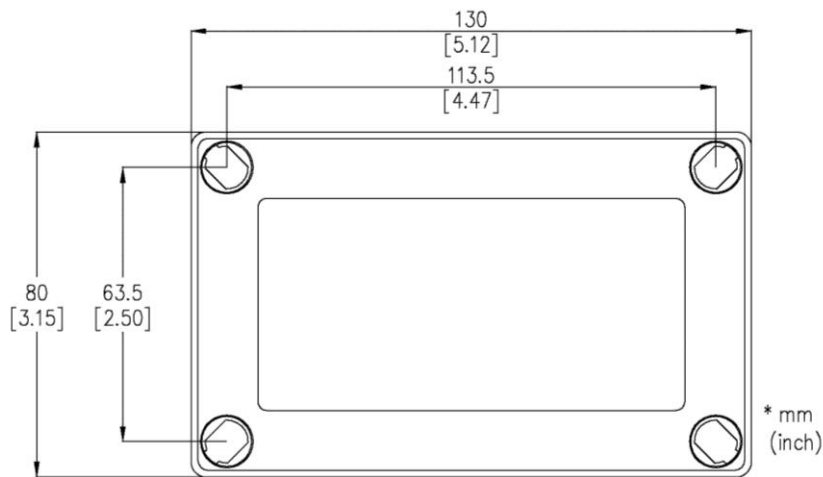

FIGURE	LENGTH	WIDTH	HEIGHT
B	130 (5.12)	80 (3.15)	75 (2.95)

Weight: 230g (8oz)

Status LED

The Status LED is used to display the current status of the station. See the table below for a definition of the different status messages.

Status LED				
Description	LED			Condition
1 Blink	•			RF Transmission Successful
3 Blinks	•	•	•	RF Transmission Failed

Conventions used throughout this manual

WARNING

Items with this label must be carefully considered otherwise harm to a product or person may result.

NOTE

Items with this label should be considered for best results.

Programming

NOTE

Please refer to the Digital Gateway II Door Controller Installation/Setup Guide for information on general menu operation and navigation.

All programming for the integrated SeyWave will be done within the SeyWave host submenu. Below is the procedure for navigating to this menu:

1. Press **Menu/Enter** to enter the Main Menu.
2. Press ▼ until the **System Config** menu is shown.
3. Press **Menu/Enter** to enter the **System Config** menu. (access level pass code may be required)
4. Press ▼ to scroll down until **Options** is highlighted.
5. Press **Menu/Enter** to enter the **Options** submenu.
6. With **SeyWave Host** highlighted, press **Menu/Enter** to enter into the **SeyWave Host** submenu.

Enabling the Integrated SeyWave Wireless

Using this menu, a user can enable or disable the integrated SeyWave. When the SeyWave is disabled, all SeyWave remote activity will be ignored. To enable or disable the SeyWave follow the steps below from the **SeyWave Host** submenu.

1. Use ▼ or ▲ until **Enable** is highlighted.
2. Press **Menu/Enter** to enter the **Enable** submenu.
3. Use ▼ or ▲ until the desired state is highlighted.
4. Press **Menu/Enter** to change the SeyWave operation state. The box to the left of the highlighted selection will be filled to indicate the current state.
5. Once the desired state has been selected, press and hold **Menu/Enter** to return to the **SeyWave Host** submenu.

Pairing Remotes

Using this menu, a user can connect compatible SeyWave remotes to the DGII. Follow the steps below from the **SeyWave Host** submenu to pair a SeyWave remote.

WARNING

Only 1 remote can be paired with a DGII at a time.

On the Remote

1. Press the **PAIR** button on the desired remote. The LED will flash.

On the DGII from the SeyWave Host Menu

1. Use ▼ or ▲ until **Pairing** is highlighted.
2. Press **Menu/Enter** to enter the **Pairing** submenu. The DGII will immediately start searching for a proximate remote in pairing mode.
3.
 - a. If a remote was found and paired, the type of remote will be displayed on the screen with the word "PAIRED" underneath it. This indicates the pairing sequence was a success.
 - b. If a remote has not been found within a certain time window, the screen will report that no remotes were discovered.
4. The menu will automatically return back to the **SeyWave Host** submenu upon completion.

Clearing Remotes

This menu is used to remove/disconnect paired SeyWave remotes and to also reset the SeyWave communication parameters. This procedure will clear all of the paired remotes from the DGII and require any remotes to be re-paired. It is not possible to only remove a single remote. Follow the procedure below to remove connected remotes.

WARNING

Performing this procedure will cause the DGII to reset the SeyWave communication. This will result in the loss of communication between any previously paired SeyWave remotes and the DGII. This includes any SeyWave remotes that may be used for safety purposes. Any SeyWave remotes being used for safety purposes must be re-paired with the DGII before door operations continue.

1. Use ▼ or ▲ until **Clear All** is highlighted.
2. Press **Menu/Enter** to enter the **Clear All** submenu.
3. A confirmation message will be displayed asking the user to confirm the operation.
4.
 - a. Press ▲ to proceed with resetting the SeyWave.
 - b. Press and hold **Menu/Enter** to abort and return to the **SeyWave Host** submenu.
5. "Clearing SeyWave" will be displayed on the screen. Once the operation has completed, the menu will automatically return to the **SeyWave Host** submenu.

Troubleshooting

Error Causes and Possible Solutions

When an operating error occurs, the error will be displayed as well as logged on the DG II. See the table below for possible error conditions.

Error Conditions					
	Message Displayed				
	E21	E22	E23	E24	
	Seywave O-C-S Comm Loss	Seywave DS Remote Timeout	Seywave DS Connection Fault	Seywave Internal Fault	
Cause	O-C-S Remote Connection Fault O-C-S Communication Loss	Door Sensor Communication Loss	Door Sensor Connection Fault	Internal Seywave has failed.	Door Sensor Battery Low

Reported Operating Errors		
Cause	Description	Possible Solutions
Connection Fault	A Remote has reported an out of range value for a monitored input.	<ul style="list-style-type: none"> - Check the Remote's connections and ensure a parallel resistor is installed. - Replace the Remote's batteries if low. - Reset communication parameters then re-pair the Remotes.
Communication Loss	A Remote has not reported to the Host within a set time allotment.	<ul style="list-style-type: none"> - Ensure the Remote is powered and that the battery level is within range. - Bring the Remote closer to the Host to check for range issue. - Reset communication parameters then re-pair the Remotes.
Internal Fault	The internal SeyWave module has failed.	<ul style="list-style-type: none"> - Check incoming power to DGII controller for fluctuations. If error persists, contact manufacturer.
Battery Low	A Door Sensor has reported a low battery.	<ul style="list-style-type: none"> - Replace the batteries in the Remote. - Reset communication parameters then re-pair the Remotes.

General Troubleshooting Topics

1. Experiencing limited or degraded RF range.
 - Ensure the Host has been mounted according to section 2.1 of this manual.
 - If possible, try to minimize the number of solid objects that the RF signal must pass through. Each intersection diminishes the RF signal.
 - Follow section 3.1 of this manual to reset the Host's communication parameters. Performing this operation will force the Host to use a different slot and channel within the 2.4 GHz band.
 - For best results, a Remote should be positioned across from a Host unit so it can receive a Remote's full RF signal propagation.
 - Contact BTR Controls if additional assistance is needed.
2. Battery life is shorter than expected.
 - Battery life is directly related to usage. Remotes with monitored inputs (O/C/S Remote & Door Sensor Remote) must consistently report themselves to the Host. If a Host unit is left unpowered for extended periods of time these Remotes are still trying to communicate with it. Every signal sent from a Remote must be acknowledged by the Host. If this acknowledgement is not received, the Remote tries up to 2 more times to send the message. Although this retry process consumes minimal power, it does consume much more power than when a Host is powered and all of the Remote messages are acknowledged on the first try.
 - Only use high quality AA alkaline batteries. Rechargeable batteries are not recommended because they tend to have a very high self-discharge rate and are not well suited for this type of application of long periods of very low power drain.